

A400 4-Leg Series Aircraft Jacks & Accessories 6,000 lb. Capacity

The A400 Series from Meyer Hydraulics has served as the general aviation industry standard for over 45 years. Professional service technicians rely on the A400 Series for the confident lifting of aircraft weighing up to 8,000 lbs. with the security and features one should demand in aircraft jacks.

Features..

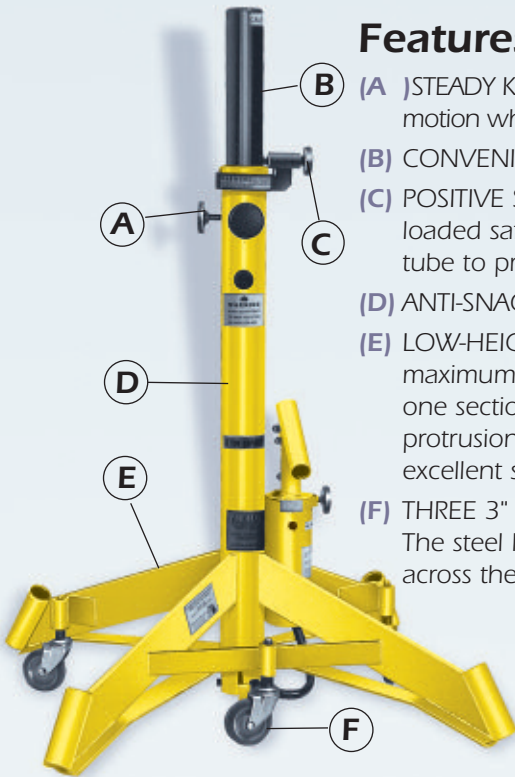

- (A) **STeady KNOBS** Prevent motion when aircraft is elevated.
- (B) **CONVENIENT HOLE SPACING**
- (C) **POSITIVE SAFETY LOCK** Spring loaded safety pin "pops" into the slide tube to prevent accidental lowering.
- (D) **ANTI-SNAG ROUND TUBE**
- (E) **LOW-HEIGHT LEG DESIGN** Provides maximum gear door clearance with one section completely free of any protrusions. The 4 legs insure excellent stability.
- (F) **THREE 3" SPRING LOADED CASTERS:** The steel leg tips never scuff across the hanger floor.

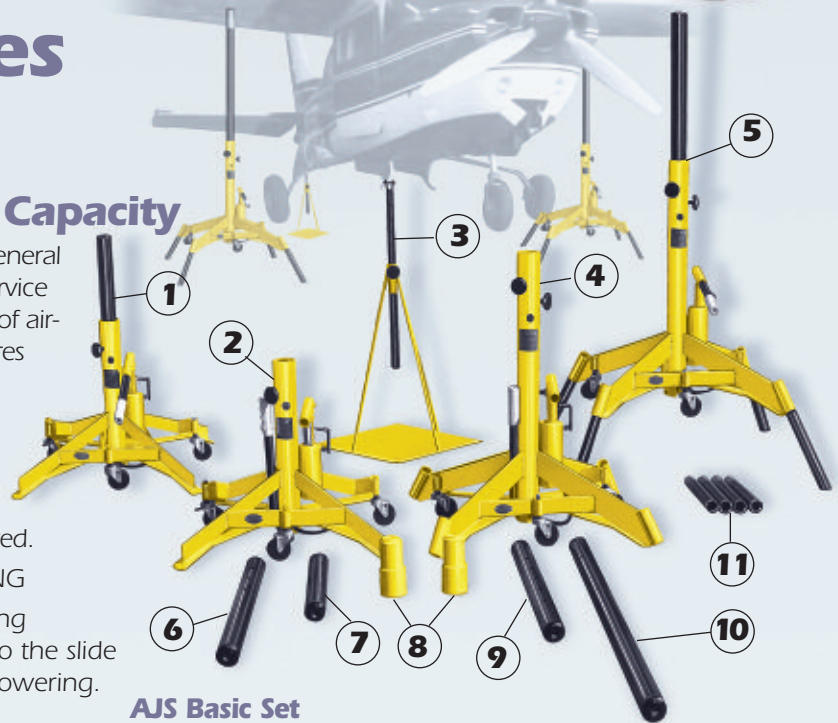

AJS Basic Set

1. A422 Jack w/AT42234 Tube
2. A422 Jack w/AT42222 Tube
3. ATS Tailstand
4. A434 Jack w/AT43434 Tube
5. A434 Jack w/AT43454 Tube & AJL Leg Set
6. AT42234 Tube
7. AT42222 Tube
8. ATC-4 Caps
9. AT43434 Tube
10. AT43454 Tube
11. AJL Leg Set

A400 Series Items	Height Ranges
A419 Jack	19"/34"
A421 Jack	21"/38"
A422 Jack w/AT42222*	22"/36"
A422 Jack w/AT42228	28"/42"
A422 Jack w/AT42234	34"/48"
A427 Jack w/AT42727*	27"/46"
A434 Jack w/AT43434*	34"/58"
A434 Jack w/AT43454	54"/78"
A434 Jack w/AJL Legs	+10"
ATC-4 Cap	+1 to 4"
ATC-8 Cap	+1 to 8"
ATS Tailstand	30"/51"
ATS w/ATS-AA72 Tube	51"/72"

(*) ATC Caps will not work on these tubes

Note: AT42228 Tubes (2) and ATC-8 Caps (2) not shown in the above AJS Basic Set photo.

AJS2 Deluxe Set

- (1) AJS Basic Set
- (1) A422 Jack w/AT42222 Tube
- (1) AT42228 Tube
- (1) ATC-4 Cap

AJS3 Premium Set

- (1) AJS Basic Set
- (2) A427 Jacks w/AT42727 Tube

A419 and A421 VeryLow Aircraft Jacks

Designed primarily for the new class of aircraft called Very Light Jets (VLJs). Each jack features an ultra low and the maximum stroke range necessary for the large landing gear movements found on these jets.



See our "Aircraft Jacks & Accessories Application Chart" for the listing of various aircraft jacking needs.



The A400 Series lifts retractable gear aircraft weighing up to 8,000 lbs.

Meyer Hydraulics Corporation

512-22 W. Burr Oak Street • Centreville, MI 49032 U.S.A.

800-253-2076 or 269-467-6302

Visit our web site at: www.meyerhydraulics.com

