

1983 Series Pump with Fixed Handle... Parts List, Assemble and Service

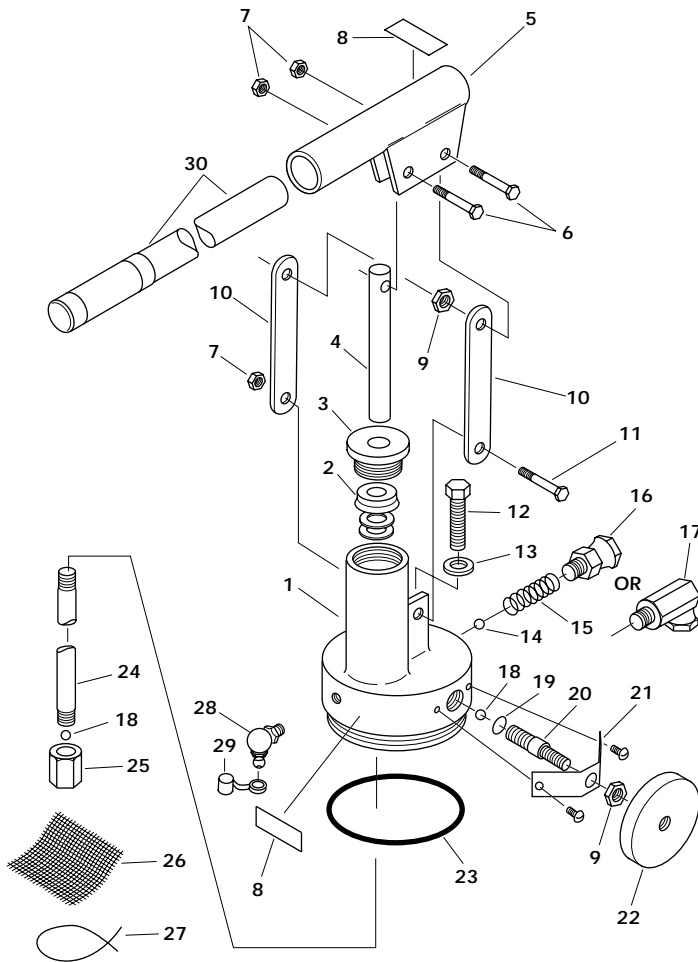

Pump Seal Installation

1. Put the thinner 18 gauge spacing washer into the pump chamber. Then put in the thicker 14 gauge spacing washer.
2. Carefully install the poly-pak seal with the lip down. Use a dull screw driver and go around the outside edges of the seal forcing slightly inwards and down. Make sure the seal lip doesn't become cut by the chamber's threads. Pack the seal down snugly against the washers.
3. Screw in the packing nut to where it bottoms out. Tighten about one-eighth turn to lock it in place.
4. Before inserting the pump piston, use the little wire gauge from the kit to check for a proper gap between the bottom of the packing nut and the top of the seal.
 - The gap must be at least the thickness of the wire, but never to where the wire can move up and down more than 1/16th inch.
 - Use any spacing washer combination to achieve a proper gap, but never remove all the washers. All spacing washers must be below the seal.

Ref. No.	Part No.	Description
1.	P-B	Pump Body
2.	HSS-100B	Hydraulic Seal Set (Seal & 2 washers)
3.	9815	Pump Packing Nut
4.	P-5	Pump Piston
5.	P-C	Pump Handle
6.	6225	Special Handle Bolt (2 per pump)
7.	6020	Nut (3 per pump)
8.	8052	Blue Cap Sticker (2 per pump)
9.	6027	Jam Nut (2 per pump)
10.	P-8	Handle Link (2 per pump)
11.	6220	Special Link Bolt
12.	6260	Pump Retaining Bolt (all-threaded)
13.	6615	Brass Flat Washer
14.	5915	5/16" Exhaust Ball Bearing
15.	5935	Exhaust Spring
16.	5630	Straight Swivel Fitting
17.	5640	90 Degree Swivel Fitting
18.	5910	1/4" Ball Bearing (2 per pump)
19.	5220	Release Valve O-Ring
20.	9820	Release Valve Stern
21.	P-RRA	Release Retainer & Screws
22.	9825	Release Knob
23.	5240	Reservoir Sealing O-Ring
24.	P-(+length)	Intake Tube
25.	9835	Intake Valve Body
26.	IS-250	Intake Screen
27.	P-19	Intake Screen Tie Wire
28.	P-13	Reservoir Air Breather Fitting
29.	5920	Blue Breather Cap
30.	EX-16	Extension Handle

K-series Repair Kits include: #2, #3, #4, #6 (2), #7 (3), #11, #13, #14, #15, #18 (2), #19, #23.

Pump Service Instructions

JACK DOESN'T RAISE, OR RAISE FULLY:

- Make sure the No. 29 Blue Breather Cap isn't covering the No. 28 Reservoir Air Breather Fitting (if your pump has this air breather system), Never put grease in this fitting.
- Check the oil level in the reservoir with the unit in an upright Position; and in a fully collapsed or lowered position. If oil runs out of the filler hole when you remove the bolt, let the excess oil drain out. Only use Hydraulic Jack Oil or MIL-H-5606 Hydraulic Fluid.

PUMP HANDLE "POPS UP", OR THE JACK'S LIFTING MECHANISM "BOBS" UP AND DOWN.

- Open the No. 20 Release Valve about one turn. Vigorously jack the No. 5 Pump Handle up and down (full stroke) about 8 times. This should flush any foreign matter stuck between the No. 14 Exhaust Ball and its seat.